

## PRESS MOUNTING CONSIDERATIONS

1-1

All too often presses are installed by simply setting them in place on the shop floor with no consideration for proper installation. Special foundations are sometimes used to provide adequate support, especially with larger tonnage presses. When used without proper support, a multitude of problems can occur, from unwanted vibrations to premature wear of press components to die failure, etc. Due to the excessive shock and vibration caused by the operation of the press, isolation material such as felt, rubber and composite have sometimes been placed under the press feet, and shims used for leveling (see figure 1).

This is a step in the right direction, but does not address the problem of fast, easy, accurate leveling and alignment of the presses, nor of maintaining alignment. For this reason the press mount was developed to provide both ease of leveling and alignment, as well as vibration isolation (see figure 2).

This development has provided cost savings for metalworking operations everywhere. The performance of a

press is greatly affected by how it is installed. The performance of other equipment, as well as personnel, are also influenced by how presses are installed. Presses should be supported in such a manner that the shock and vibration generated in normal operation does not transmit into surrounding areas, thereby disrupting precision machining work and/or contributing to personnel fatigue.

*Press mounts have provided a way to allow presses to perform at optimum levels, while reducing the cost of installation, operation and maintenance. Other cost savings include fewer scrap parts and less building damage to floors, foundations, etc.*

In order to perform to design specifications, presses must be supported adequately to maintain alignment and critical relationships between press and feed equipment.

The support system for a press must be capable of dealing with:

1. Static loads (dead weight of the press)
2. Stamping impacts and snap-through forces
3. Slide inertia forces
4. Rotating out-of-balance forces

To determine whether or not a press is a good candidate for the use of press mounts, let's briefly examine each of the four items listed above.

**1. Static loads** are the forces seen at each mounting point with the press in operating position, but completely at rest. Most presses have four mounting points, but are constructed so that the weight is not evenly distributed among them. Usually the rear feet are farther from the center line of the slide travel than the front feet. Also, flywheels and drive equipment on mechanical presses are located on one side or another. This uneven distribution of weight must be taken into account when designing any support system. UNISORB® *Quantum PM™* Press Mounts make it possible to compensate for unequal weight distribution by allowing adjustment of loading among the press feet.

**2. Stamping impact and snap-through forces** are present to some degree in all presses and can be particularly troublesome when higher speed machines are used for blanking. The rapid rate of rise of force as the stock is contacted by the punch moves the press crown upward and the bed downward, stretching the press uprights in the process. At maximum capacity, the uprights of a press could be stretched to their allowable limits. When the work material fractures, the opposite action occurs with the press crown moving downward and the bed upward to its original position, and because of this inertia, slightly beyond. This reaction is called snap-through shock. These forces are magnified by any misalignment condition which exists within the press. Both the stamping impact and snap-through forces can be greatly reduced by proper leveling of the press, thus assuring proper alignment of press components. Press mounts are very useful for controlling these forces and assuring symmetrical loading of the press structure, thus greatly enhancing component life.

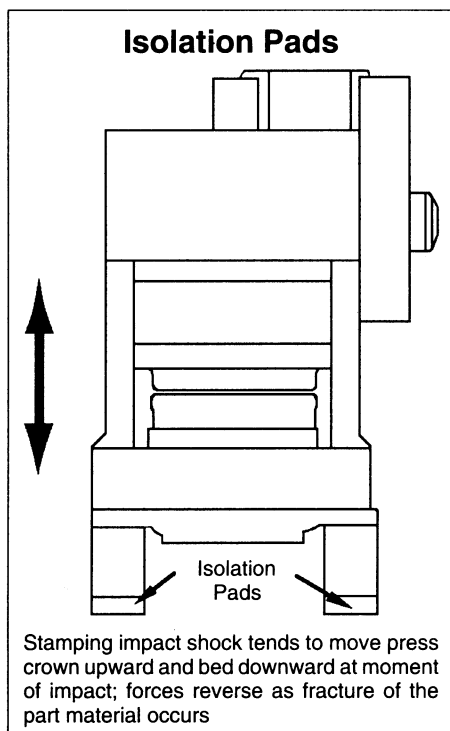

Figure 1

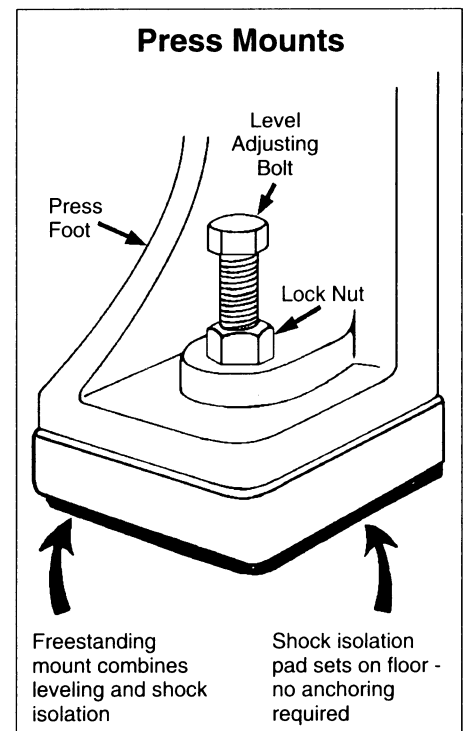

Figure 2

(continued)

**3. Slide inertia forces** result from acceleration forces acting on the slide and are an extremely important consideration in the design of a press mounting system. They act primarily in the direction of slide travel and tend to alternately lift the press from its supporting surface and push it back into its supporting surface. In some high speed presses it is possible for these forces to exceed the dead weight of the press. This condition establishes a limitation as to whether or not a press should be mounted on freestanding mounts. Machines which are manufactured with dynamic balancing equipment do not have this problem, and can safely be mounted on press mounts. Older high speed presses should be securely bolted down, and are good candidates for isolated foundations (see figure 3).

**4. Rotating out-of-balance forces** result from crankshaft imbalance and produce a rocking of the press about its mounting points. This problem is usually found in older presses which do not have dynamic balancing equipment, and which are being operated at high speeds. In cases like this, proper action must be taken to restrain the press. When this condition exists on a press it is possible to predict by calculation the amplitude of the rocking motion that will occur if sufficient engineering data can be obtained on the press. Otherwise, a stiffer than normal installation must be furnished to minimize the rocking motion. This condition also is well suited to the isolated foundation approach.

Anytime a press cannot be mounted safely on press mounts due to any of the above conditions, UNISORB® offers the perfect solution. UNISORB® Inertia Block materials, used in conjunction with a well engineered foundation with proper anchoring, will reduce the vibration and impact problems associated with the operation of these machines, while maintaining the rigidity needed for proper support. In some

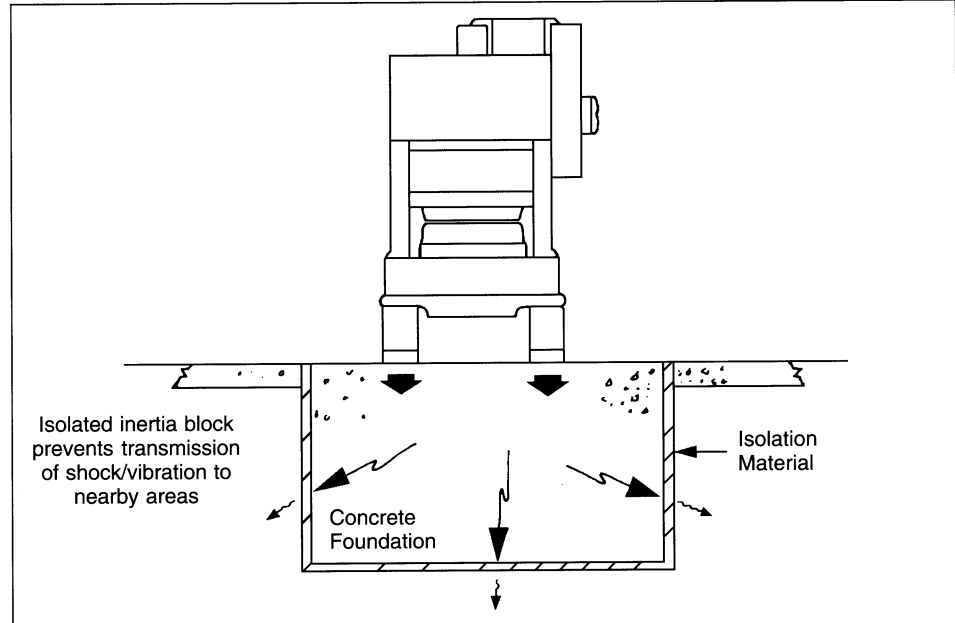

Figure 3

cases presses have been mounted using both press mounts and inertia blocks, thus providing ease of leveling while further tuning out vibration problems. Contact UNISORB® Engineering for more information about the inertia block isolation materials.

In lieu of constructing an isolated foundation, UNISORB® isolation pads can be placed under the press feet, and the press securely bolted to the floor, with leveling accomplished by the use of shims. UNISORB® Vector™ Anchor Bolts, together with either UNISORB® V-1® Non-Shrink Machinery Grout (cement-based) or V-100® Epoxy Grout, can be used to anchor the press feet to the floor. Contact UNISORB® Engineering for more information on these fine products.

By utilizing press mounts whenever possible, anchor bolts, steel plates, shims and grouting materials can be eliminated, thus saving time and money. Any savings in labor and down time can be considered to be significant financial gain. These savings also can be

realized any time a press is relocated. Other savings which can be attributed to the use of press mounts are related to reduced maintenance of presses, dies, foundations and floors.

Two very important design considerations should be taken into account when press mount evaluations and selections are made:

- A. Press mount construction**
- B. Isolation pad material selection**

**A. Press Mount Construction** is critically important because of the tremendous pounding inflicted upon the mount during press operation. UNISORB® has optimized the balance between the high quality and strength of ductile cast iron and structural steel for its housing construction. The ductile cast iron is used on the smaller mounts, while the larger mounts utilize the structural steel components. The ductile cast iron offers the best combination of strength and economy for our

## PRESS MOUNTING CONSIDERATIONS

(continued)

1-3

smaller Press Mounts (PM-61 thru PM-201).

Due to the necessity for flexibility of size and shape, the PM-261 models and larger are manufactured using structural steel. All the UNISORB® *Quantum PM™ Press Mount* components are rugged enough to suit any press application. UNISORB® has the option of using structural steel for any of its press mount sizes if the need for special size or shape mounts arise. UNISORB® *Quantum PM™ Press Mounts* have also maintained the popular design feature of the spherical dimple in the impact plate under the adjusting bolt to allow for angular correction for uneven floors. For the above reasons Unisorb has maintained its position as the most versatile supplier of press mounts in the industry.

**B. Isolation pad material selection** is paramount because it determines the degree of proper vibration isolation and environmental conformity which may be achieved by using press mounts. The design and construction of UNISORB® *Quantum PM™ Press Mounts* provides the capability of choosing from a variety of isolation pad designs. These products are selected on the basis of their individual characteristics to meet your exact isolation needs. This flexibility provides the opportunity to maximize vibration isolation and take into account shape factors, environmental conditions, spring rates, etc. Therefore UNISORB® is not restricted to the use of any one type of pad material. UNISORB® elastomeric pads are molded to exacting specifications to achieve optimum shock, damping and vibration control. UNISORB® Titan™ Shock Pads provide excellent vibration control and damping, especially under extreme loads and high shock applications. A combination of Elastomeric Pads together with Titan

Shock Pad inserts offer the perfect solution to solving the vibration/isolation problems on larger presses (see Figure 5). UNISORB® Elastomeric Pads are impervious to fluid absorption and provide excellent isolation and damping. The high quality molded compound is superior to industrial neoprenes in oil resistance and damping. Urethanes and other elastomers are also available, if needed, to meet the special requirements of the Food and Drug Administration and the U.S. Department of Agriculture.

UNISORB® *Quantum PM™ Press*

*Mounts* have a special "Friction Kote" available on the bottom surface of the resilient pads to prevent presses from "walking" on shop floors.

Finally, as "the proof of the pudding is in the eating," so "the value of a press mount is in the performance." UNISORB® *Quantum PM™ Press Mounts* outperform others in reducing shock and vibration. Please see pages 5-1 and 5-2 of this manual for vibration curves illustrating this.

UNISORB® has many satisfied press mount customers, and a list of referrals is available on request.

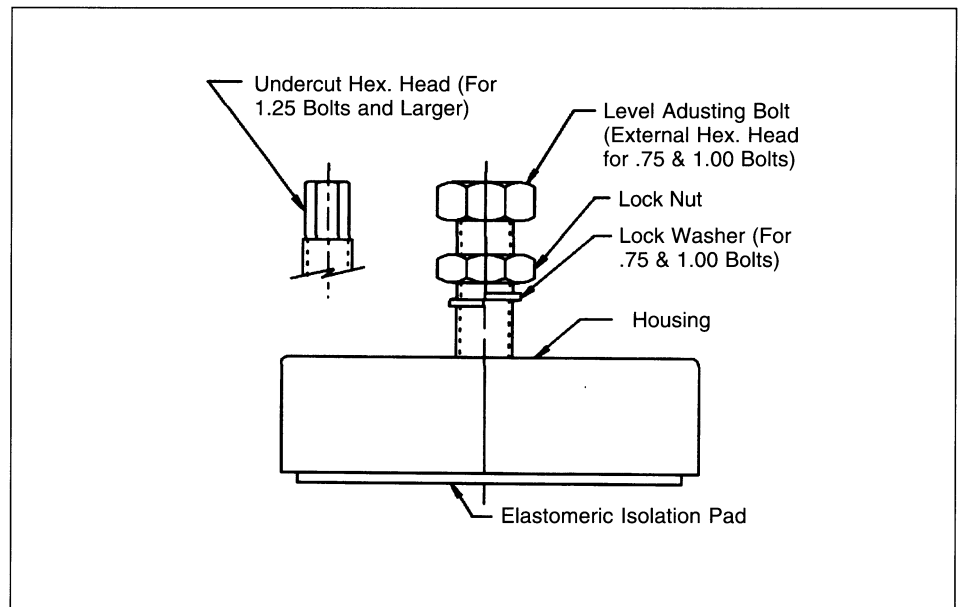
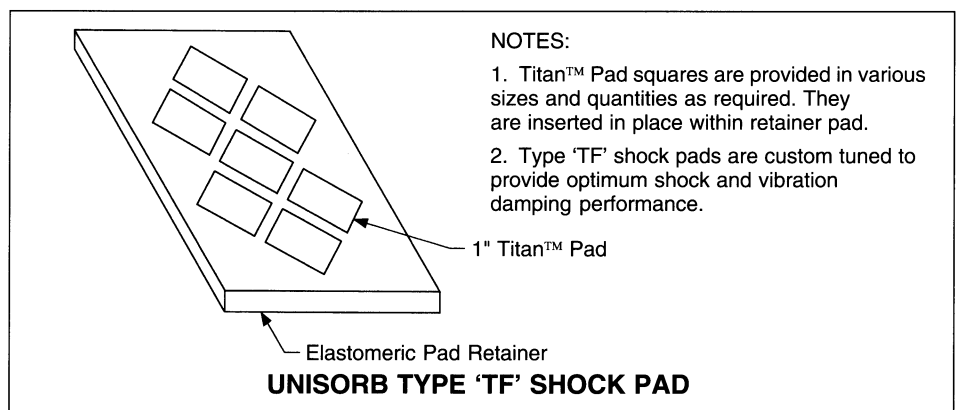

Figure 4



**NOTES:**

1. Titan™ Pad squares are provided in various sizes and quantities as required. They are inserted in place within retainer pad.
2. Type 'TF' shock pads are custom tuned to provide optimum shock and vibration damping performance.

Figure 5